

Report ID:	26,114,910	Version:	1
Created:	06 May 2026		

Make:	Mahindra	Model:	XUV
Body Style:	SUV	Year:	2025
Rego No.:	RJA250	Rego Expiry:	07 Aug 2026
WoF Expiry:	08 Aug 2028	Odometer:	23,450 Kms
Good No.:	26114910	VIN:	MA1NY2NWPS2E63646
Next Service:	due	Service History:	No

**Note: This report is not a warranty**  
 This report is a guide only. Consideration is made for age and mileage. Parts have not been dismantled or diagnostic testing undertaken. The vehicle has been driven up to 50km/h from cold. The Vendor recommends a full mechanical inspection prior to purchase and this can be arranged for an additional charge.

**Key**  
 S = Scratch    R = Rust    C = Crack    \* = Decals    W = Significant scuffs  
 D = Dent    PT = Paint defect    P = Pin dent    SC = Stone Chips

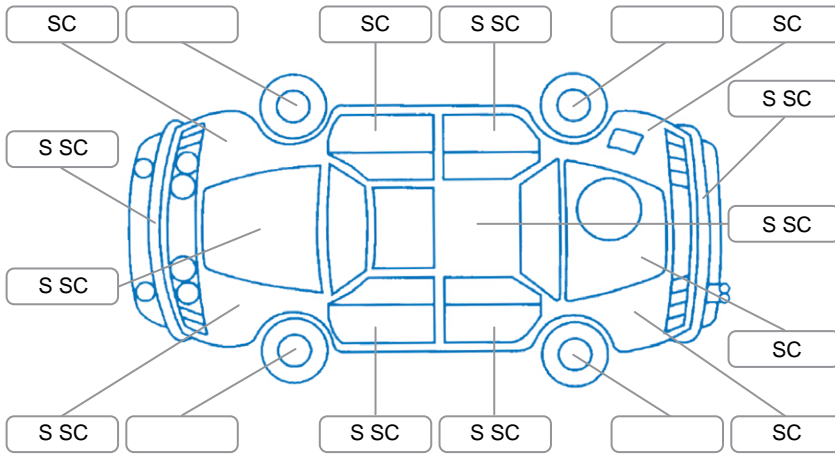

Note: some defects and blemishes may not be displayed in the diagram

### Body Inspection Comments

Engine check light on/boot don't open needs attention/

Conditions During Body Inspection

Wet

### Under Carriage and Under Bonnet Inspection Comments

2wd

### Interior Comments

Seats:	Average
Carpets:	Average
Panels:	Average
Dashboard:	Average

### General Comments

Road Conditions During Test Drive	Dry		
Engine Timing Mechanism	Timing Chain		
Evidence of Cam Belt Replacement	<input type="checkbox"/> Yes	<input type="checkbox"/> No	Kms
Inspected by:	Uriah Pepene		
Published by:	Uriah Pepene		
Inspection Date:	06 May 2026		

	OK	Requires Attention	N/A
<b>Engine</b>			
Oil level	✓		
Smoke & fumes	✓		
Engine performance	✓		
Noise	✓		
Coolant condition	✓		
Cooling performance	✓		
Radiator / Hoses (visual)	✓		
<b>Transmission</b>			
Operation	✓		
Noise	✓		
Clutch			✓
CV joints	✓		
Wheel bearings	✓		
<b>Brakes</b>			
Performance	✓		
Hand brake	✓		
<b>Tyres (lowest observed tread depth of tyres)</b>			
Left front			5.5 mm
Right front			5.5 mm
Left rear			5.5 mm
Right rear			5.5 mm
Spare		Yes	
<b>Suspension</b>			
Suspension performance	✓		
Steering performance	✓		
Shock absorbers	✓		
<b>Air Conditioning / Heater</b>			
Operation	✓		
<b>Electrical / Accessories</b>			
Head lights	✓		
Tail lights	✓		
Indicators	✓		
Dashboard warning lights		✓	
Wipers (front & rear)	✓		
Window winder FL	✓		
Window winder FR	✓		
Window winder RL	✓		
Window winder RR	✓		
Rear view mirrors	✓		
Radio (basic test only)	✓		
CD (basic test only)	✓		
Number of keys	1		
Central locking	✓		
Remote locking	✓		
Sat. nav. (basic test only)			✓
Reversing camera	✓		

I have read and understood this condition guide:

NAME \_\_\_\_\_

SIGNATURE \_\_\_\_\_